



厦门华联半导体科技有限公司

Xiamen Hualian Semiconductor Technology Co., Ltd.

产品规格书

SPECIFICATION

产品名称：高速逻辑门输出型光耦合器

DESCRIPTION: High Speed Logic Gate Opto-coupler

产品型号：HPL6S135

PART NO.: HPL6S135

拟制 Prepared	审核 Verified	批准 Approved

电话 Tel: 86-0592-2950777

传真 Fax: 86-0592-6037471

网址 Web: www.xmhl.com

地址：厦门市翔安区舫阳南路 189 号

Add: No.189,Fangyang South Road,Xiang'an District,Xiamen China

1 概述 General

光耦产品 HPL6S135 由砷化铝镓红外发光二极管与高速逻辑门光敏芯片耦合封装构成，数据传输速率可达到 1 Mbit/s。正常工作温度可达-40°C to +110°C，产品具有很强的共模抑制能力。



图 1 产品 Figure 1-Product

The HPL6S135 optocouplers consist of an AlGaAS LED, optically coupled to a very high speed integrated photo-detector logic gate with a strobable output, and the data transmission rate can reach 1 Mbit/s. The coupled parameters are guaranteed over the temperature range of -40°C to +110°C. Products have strong common mode rejection capability.

2 特点 Features

- 数据传输速率快。High speed:1 Mbit/s .
- 逻辑门输出。Logic gate output.
- 双列贴片式 5L 塑料封装 SOP 5L Plastic Package
- TTL/LSTTL 兼容。TTL/LSTTL Compatible:5V supply
- 符合 RoHS 指令最新要求及 REACH 法规最新要求。Compliance with the latest requirements of the RoHS Directive and the latest REACH requirements.
- 产品符合 UL/cUL、VDE、CQC 安规认证。The products comply with UL/cUL,VDE,CQC safety certification. UL/cUL 证书编号：E178703；VDE 证书编号：40004708；CQC 证书编号：CQC22001340049
UL/cUL Certificate No. E178703; VDE Certificate No. 40004708; CQC Certificate No. CQC22001340049

3 应用 Applications

- 线接收器。Line receivers.
- 数据传输。Data transmission.
- 计算机外围接口。Computer-peripheral interface.
- 替代脉冲变压器。Pulse transformer replacement.
- 开关电源。Switching power supply.

4 电原理图 Schematic Diagram



图 2 电原理图
Figure 2-Schematic

表 1 真值表

Table 1-Truth Table

LED	Output
ON	L
OFF	H

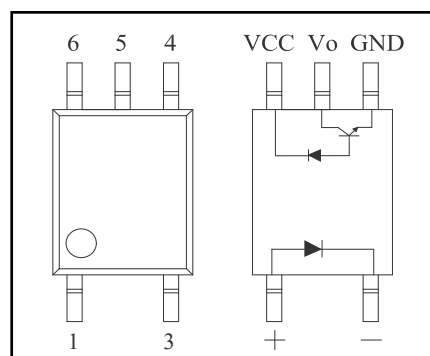
5 极限参数 Absolute Maximum Ratings

表 2 极限参数

Table 2-Absolute Maximum Ratings

Ta=(25±5)°C, RH=30~75%

参数名称 Characteristic		符号 Symbol	额定值 Rating	单位 Unit
输入端 Input	正向电流 Forward Current	I _{FM}	25	mA
	反向电压 Reverse Voltage	V _R	5	V
	耗散功率 Power Dissipation	P _M	45	mW
输出端 Output	输出电流 Output Current	I _O	8	mA
	输出峰值电流 Peak Output Current	I _{OP}	16	mA
	电源电压 Supply Voltage	V _{CC}	-0.5~30	V
	输出电压 Output Voltage	V _O	-0.5~20	V
	输出端功耗 Output Power Dissipation	P _c	100	mW
工作温度 Operating temp.		T _{aop}	-40 ~ +110	°C
贮存温度 Storage temp.		T _{stg}	-55 ~ +125	°C
焊接温度 Soldering Temperature	手工焊 Hand Soldering (3 Sec.)	T _{sld}	360	°C
	回流焊 Reflow Soldering (5 Sec.)		260	°C
绝缘电压 Isolation voltage (RH≤60%,交流 1 分钟) (RH≤60%, AC 1min.)		V _{ISO}	3750	V _{rms}

6 电参数 Electrical Parameters

表 3 光电参数

Table 3-Opto-Electrical Characteristics

Ta=(25±5)°C, RH=30~75%

参数名称 Characteristic		符号 Symbol	测试条件 Test Conditions	最小值 Min.	典型值 Typ.	最大值 Max.	单位 Unit
输入端 Input	正向电压 Forward Voltage	V _F	I _F =16mA		1.35	1.7	V
	反向输入压降 Input Reverse Breakdown Voltage	BV _R	I _R =10μA	5			V
输出端 Output	高电平输出电流 Logic High Output Current	I _{OH}	V _O =V _{CC} =5.5V I _F =0 mA		3	500	nA
			V _O =V _{CC} =15V I _F =0 mA			50	μA

	低电平供给电流 Logic Low Supply Current	I_{CCL}	$V_O=Open$ $V_{CC}=15V$ $I_F=16mA$		0.5	0.8	mA
	高电平供给电流 Logic High Supply Current	I_{CCH}	$V_O=Open$ $V_{CC}=15V$ $I_F=0mA$		0.01	2	μA
耦合 Coupler	电流传输比 Current Transfer Ratio	CTR	$I_F=16mA$ $V_{CC}=4.5V$ $V_O=0.4V$	20			%
	低电平输出电压 Logic Low Output Voltage	V_{OL}	$I_F=16mA$ $V_{CC}=4.5V$ $I_O=2.4mA$		0.18	0.4	V
开关 Switching	输出端逻辑由高到低的传输延迟 Propagation Delay Time to Logic Low at Output	t_{pHL}	$V_{CC}=5V$ $R_L=1.9k\Omega$ $I_F=16mA$		0.2	1.0	μs
	输出端逻辑由低到高的传输延迟 Propagation Delay Time to Logic High at Output	t_{pLH}	$V_{CC}=5V$ $R_L=1.9k\Omega$ $I_F=16mA$		0.5	1.0	μs
	输出端为高电平时的共模抑制比 Common Mode Transient Immunity at Logic High Level Output	CM_H	$R_L=1.9k\Omega$ $I_F=0mA$ $V_{CM}=1.0kV_{P-P}$	15000			V/ μs
	输出端为低电平时的共模抑制比 Common Mode Transient Immunity at Logic High Level Output	CM_L	$R_L=1.9k\Omega$ $I_F=16mA$ $V_{CM}=1.0kV_{P-P}$	-15000			V/ μs
	带宽 Bandwidth	BW	$R_L=100\Omega$		2		MHz

7 特性曲线图 Characteristic Curve



图 3 V_F - I_F 特性曲线



图 4 CTR- I_F 特性曲线

Figure 3-Typical input diode forward characteristic Figure 4 Current Transfer Ratio vs. Forward Current

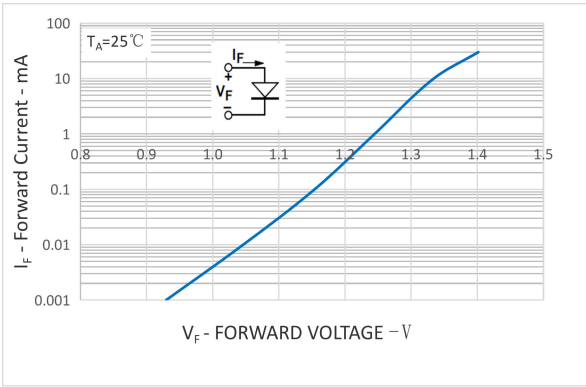

图 5 I_O - T_A 特性曲线

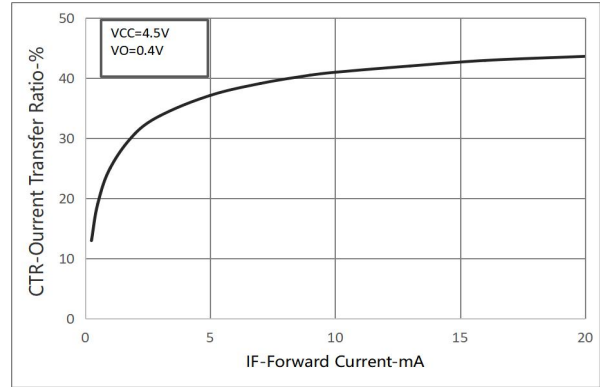
Figure 5-Output Current vs. Temperature

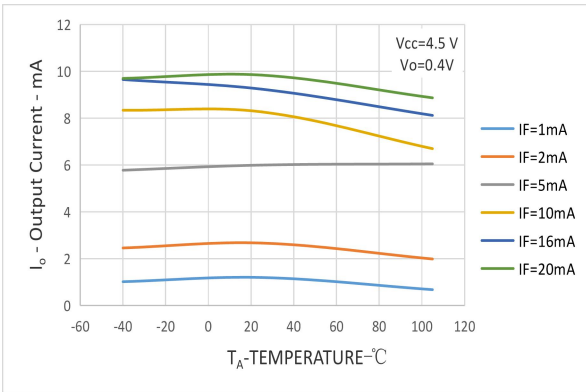

图 6 t_P - T_A 特性曲线

Figure 6-Propagation Delay vs. Temperature

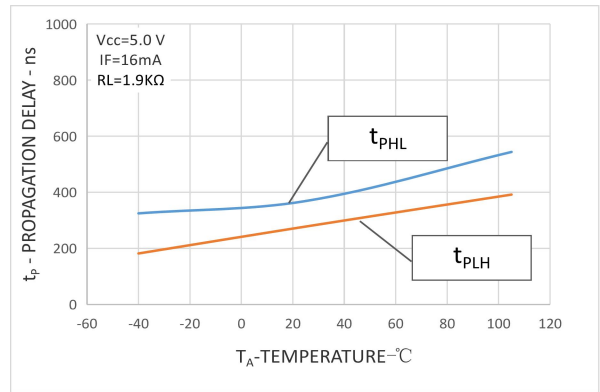

图 7 I_{CCL} - T_A 特性曲线

Figure 7-Supply Current vs. Temperature

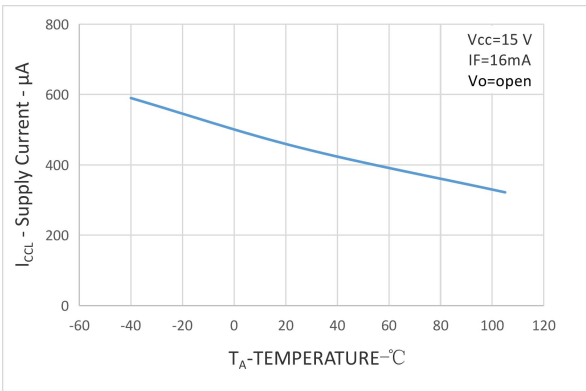

图 8 V_{OL} - T_A 特性曲线

Figure 8-Logic Low Output Voltage vs. Temperature



图 9 t_{PHL} 、 t_{PLH} 测试电路
Figure 9- The test method of t_{PHL} 、 t_{PLH}

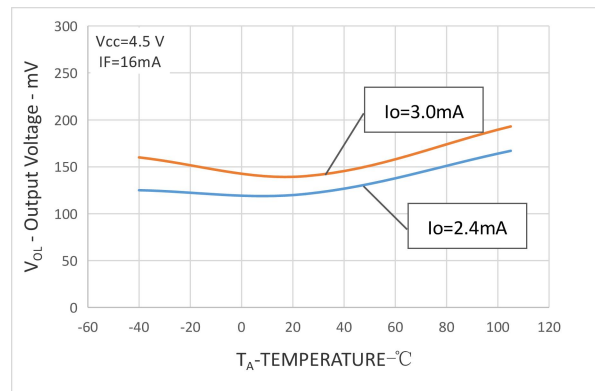

图 10 CMR 测试电路
Figure 10- Test Circuit for Transient Immunity and Typical Waveforms

8 外形尺寸图 Dimensions Diagram

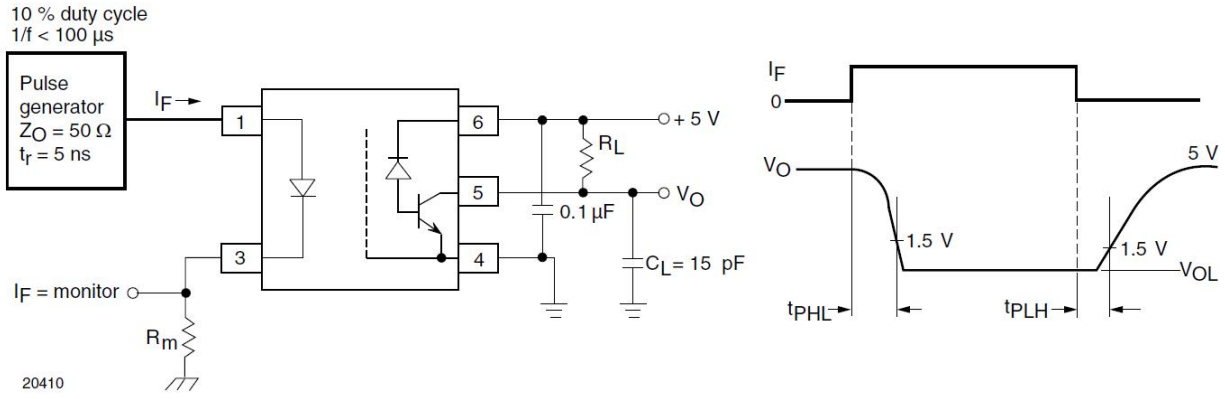

技术要求:
1. 未注公差: ± 0.20

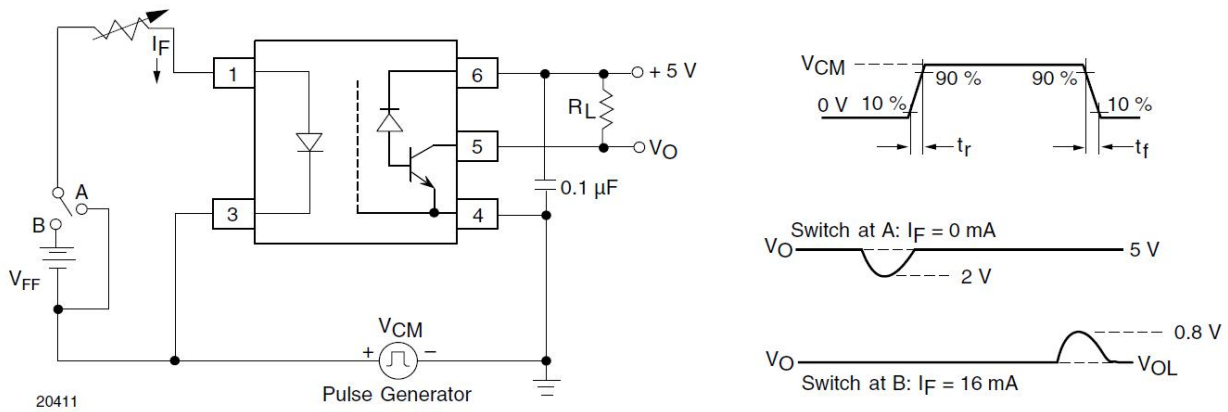
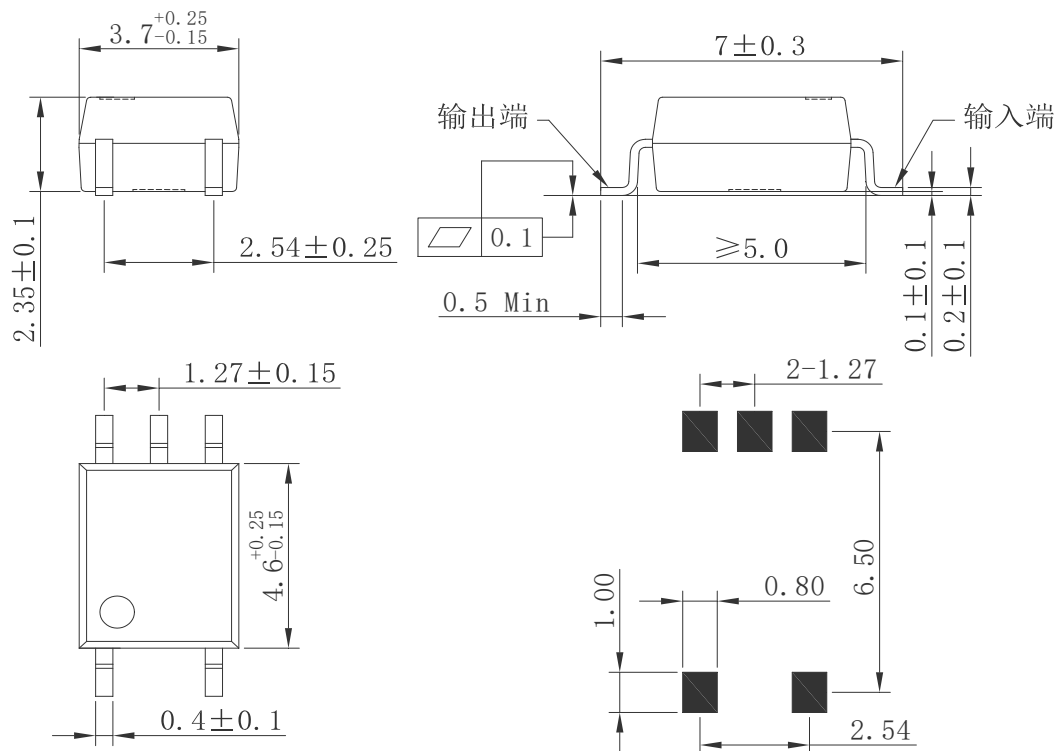
推荐焊盘尺寸
Recommended pad size

图 11 HPL6S135 外形尺寸

Figure 11- The dimensions of HPL6S135

9 标志 Mark

产品上应有型号、公司商标、生产日期代码、引出端识别标记。例如：HPL6S135 产品印章如图 12。

Print type characters, trade mark and Lot. No. on the Photo-transistor Coupler. For example the marking of product HPL6S135 is shown as Figure 12.

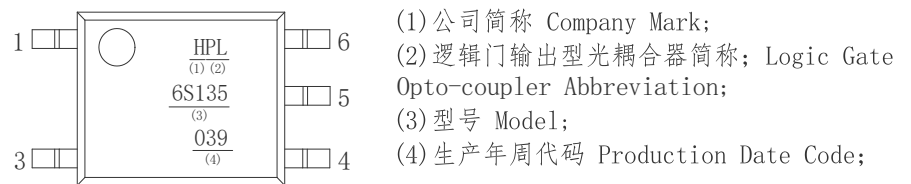

- (1) 公司简称 Company Mark;
- (2) 逻辑门输出型光耦合器简称; Logic Gate Opto-coupler Abbreviation;
- (3) 型号 Model;
- (4) 生产年周代码 Production Date Code;

图 12 产品印章

Figure 12- Marking

10 包装方式 Packing

10.1 编带包装 (Tape and reel) : 适用于 For HPL6S135

10.1.1 每卷数量 (Qty/reel) : 3000 只 (pcs)。每箱数量 (Qty/ctn) : 60000 只 (pcs)。

10.1.2 内包装 (Inner packing) :

每卷盘 3000 只, 贴合格证 (型号、生产日期代号、检验员代号)。

3000pcs/reel, certificate on reel (model, code of product date, Inspector' s code)

10.1.3 外包装(Outer packing):

公司名称、地址、商标、产品型号、数量等标志。

Indication of company name, address, trade mark, model and quantity.

10.1.4 示意图 (Schematic) :



图 13 编带包装示意图
Figure 13- Taping Packing Schematic

11 使用注意事项 Note

11.1 推荐贮存温度 Recommend storage Temp.: 0~40°C;

推荐贮存湿度 Recommend storage humidity: <60%;

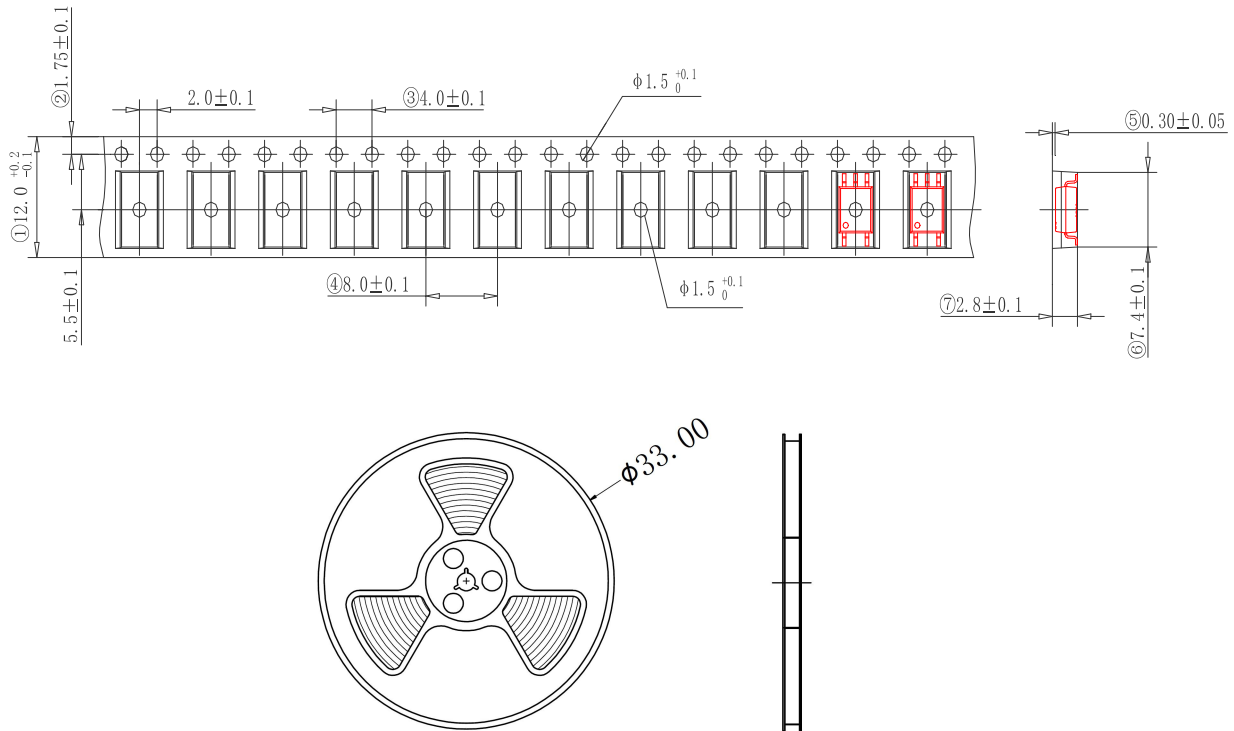
湿气敏感度等级 1 级。MSL level: MSL 1.

11.2 引脚镀锡厚度: 大于等于 5μm。

Thickness of Sn which plated on lead frame: ≥5μm.

11.3 推荐焊接条件 Recommended Soldering Conditions

11.3.1 请勿使用超过最高贮存温度的物体直接接触环氧本体。

Do not contact the epoxy body directly with objects exceeding the maximum storage temperature.

11.3.2 在高温下不要对环氧本体施加压力, 特殊情况下施加的力不应超过 2.5N。

Do not apply pressure to the epoxy at high temperatures, and in special cases do not apply more than 2.5N.

11.3.3 回流焊 Reflow soldering

1) 推荐锡膏规格 Recommend tin glue specifications:

a) 熔点 Melting temperature: 217°C

b) 组分 Contains: SnAg3Cu0.5

2) 回流焊工序必须在器件冷却至室温后进行。Never take next process until the component is cooled down to room temperature after reflow.

3) 推荐回流焊接参数, 如下图所示: The recommended reflow soldering profile is following:

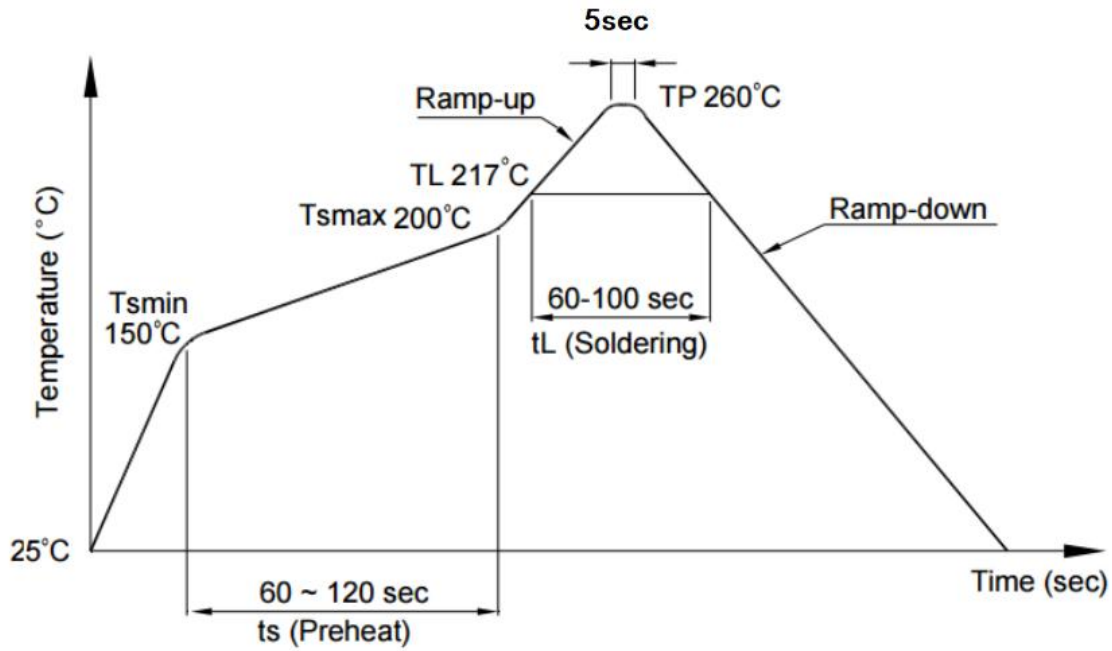

项目 Items		条件 Conditions
预热 Preheat	Temperature Min (T_{Smin})	150°C
	Temperature Max (T_{Smax})	200°C
	Time (min to max) (t_s)	90±30 sec
焊接区 Soldering zone	Temperature (T_L)	217°C
	Time (t_L)	60 ~ 100 sec
最高温度 Peak Temperature (T_P)		260°C
升温速率 Ramp-up rate		3°C / sec max.
降温速率 Ramp-down rate		3~6°C / sec

图 14 回流焊参数

Figure 14-Recommended reflow soldering profile

4) 建议在所示的温度和时间条件下进行一次回流焊,最多不能超过三次。One time soldering reflow is recommended within the condition of temperature and time profile shown below. Do not solder more than three times.

11.3.4 手工烙铁焊 Manual soldering

1) 手工烙铁焊仅用于产品返修或样品测试。Manual soldering is only applicable to product repair.

2) 手工烙铁焊要求: 温度 $360^{\circ}\text{C} \pm 5^{\circ}\text{C}$, 时间 $\leq 3\text{s}$, 返修次数 ≤ 2 次。Manual soldering requirements: temperature $\leq (360^{\circ}\text{C} \pm 5^{\circ}\text{C})$, time $\leq 3\text{s}$, repair times ≤ 2 times.

11.4 本说明书所展示的产品是为一般电子应用而设计的,如办公自动化设备、通讯设备、视听设备、电气应用和仪器仪表等。对于需要高可靠性或安全性的设备,如空间应用、核动力控制设备、医疗设备等,请与我们的销售代表联系。The products shown in this publication are designed for the general use in electronic applications such as office automation equipment, communications devices, audio/visual equipment, electrical application and instrumentation. For equipment/devices where high reliability or safety is required, such as space applications, nuclear power control equipment, medical equipment, etc, please contact our sales representatives.

12 产地 Production Place

12.1 产地 Production Place: 中国厦门 Xiamen China;

12.2 工厂名称 Production NO.: 厦门华联半导体科技有限公司; Xiamen Hualian Semiconductor Technology Co., Ltd.;

12.3 工厂地址 Production Add.: 厦门市翔安区舫阳南路 189 号 No.189, Fangyang South Road, Xiang'an District, Xiamen China.

更改记录表
Engineering Change Notice-Record

版次 Edition	更改日期 Date	主要更改内容 Main Content	拟制 Prepared	确认 Checked
1.0	2019-03-01	新版发行;	王梓建	段果
1.1	2019-08-03	版本格式更新;	黄发宝	段果
1.2	2019-09-30	变更表 2 中 CTR 的测试条件及规格限值;	黄发宝	段果
1.3	2020-07-23	1. 产品型号 HPL6N135-MS5 变更为 HPL6S135; 2. 产品总长尺寸 7.2 ± 0.3 调整为 7.0 ± 0.3 ; 3. 每箱的包装数量由 45000 只变更为 60000 只; 4. 编带材料的宽度尺寸由 16mm 变更为 12mm; 5. 湿敏等级由 3 级调整为 1 级; 6. 电镀层厚度 $\geq 5 \mu\text{m}$, 调整为 $\geq 3 \mu\text{m}$ 。	黄发宝	段果
1.4	2020-11-13	图 4 的印章格式变更;	黄发宝	段果
1.5	2021-06-03	表 2 的开关时间上限由 $1.5 \mu\text{s}$ 调整为 $1.0 \mu\text{s}$	黄发宝	段果
1.6	2021-06-22	1.电源电压由 $(-0.5 \sim 15)\text{V}$ 调整为 $(-0.5 \sim 30)\text{V}$; 2.输出电压由 $(-0.5 \sim 15)\text{V}$ 调整为 $(-0.5 \sim 20)\text{V}$; 3.低电平供给电流 ICCL 由 $\leq 0.2\text{mA}$ 调整为 $\leq 0.8\text{mA}$ 。	黄发宝	段果
1.7	2021-09-29	新增第 6 项产品特性曲线图及测试电路。	黄发宝	段果
1.8	2022-10-25	1. 工作温度上限 85°C 变更为 105°C 2. 删除 10.2 标识 Label 3. 表 2 部分电参数项目调整 4. 变更工厂地址	张强龙	段果
1.9	2022-12-29	1. 删除邮编; 2. 工作温度上限由 105°C 调整为 110°C ; 3. 图 3 CTR-IF 特性曲线更新; 4. 更新 10.2 注意事项。	张强龙	黄发宝
1.10	2023-10-08	1. 新增安规认证说明以及证书编号, 新增 RoHS、REACH 说明。	张强龙	黄发宝
1.11	2023-11-02	1、公司名称变更为华联半导体科技有限公司; 2、图 11 外形尺寸图新增推荐焊盘尺寸。	姚彭彭	黄发宝